

NOTE: CARTON MATERIAL MUST BE A=A

REVISION INFORMATION

Rev.	Rev. Date	Modified By	Brief Description

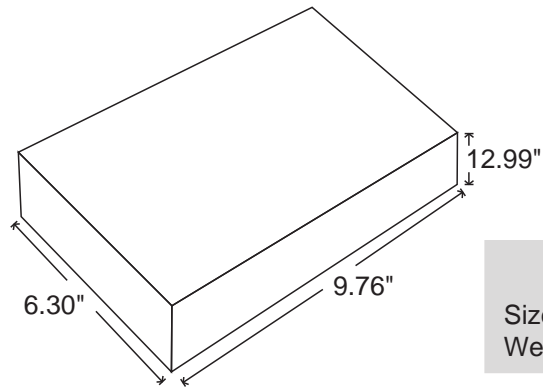

Unit package
 Size: 9.76" (L)*6.30"W*12.99"(H)
 Weight: 10.6LBS

P/O:
 P/N: 502887
 Q'TY:
 C/NO.:

 MADE IN CHINA

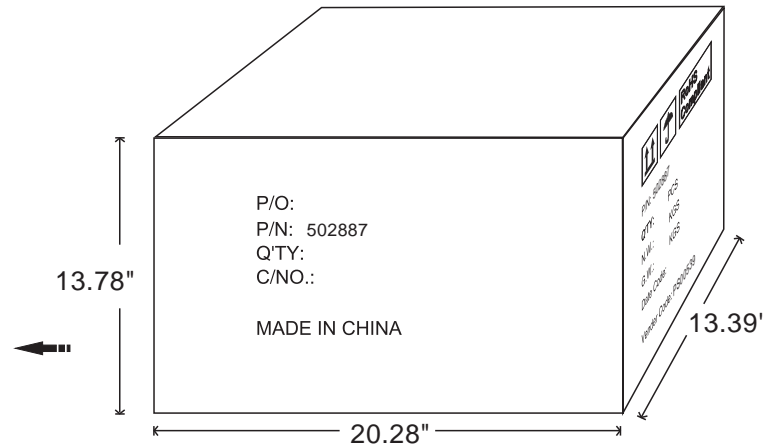

Carton Size: 20.28"(L)*13.39"(W)*13.78"(H)
 Carton Quantity: 4pcs
 Carton Weight: 43.65LBS

		RoHS Compliant
P/N: 502887		
Q'TY:	PCS	
N.W.:	KGS	
G.W.:	KGS	
Date Code:		
Vender Code: PS00539		

DRAWN BY	DATE: 2021/3/26	DESCRIPTION: CORNER FULL-MOTION TV WALL MOUNT LPA63-446C	
CHECKED BY	SHEET 1 of 2	ITEM NO. 502887	
APPROVED BY	SCALE 1:1	REV. 00	UNIT:mm